

ZOOMLION

NEW

ROUGH TERRAIN

ELECTRIC ARTICULATING BOOM LIFTS

ZA20JERT/ZA20JERT-Li

Comply with ANSI/CSA Standard

HIGHLIGHTS

- ▶ Provide greater work height of 21.38m and lift capacity of 250kg/360kg than competitor
- ▶ Fast lift system directly lowers the boom from the highest position to the ground, no need to fold the boom to improve work efficiency
- ▶ Accurate and efficient traveling AC drive system and on-board motion AC drive system provides strong power, stable control and maintenance-free motor
- ▶ Independent auxiliary power system for more secure application
- ▶ Large reduction ratio reducer provides stronger gradeability
- ▶ Large-capacity lithium battery features long-lasting battery life, and number of charge and discharge cycles reaches 2500 times, the whole life cycle is maintenance-free, and a 5-year warranty is provided

FEATURES

Standard Features

Proportional control
All motion alarm
Flashing beacon
Self-closing entry gate
Emergency descent system

Emergency stop button
Auto-leveling system
On-board diagnostic system
Over tilt protection system
Oscillating axle

Load sensing system
4.3' LED display
Horn
Anti-crushing device
Fast lowering function

Accessories & Options

Platform light
AC power to platform
Airline to platform
2.44×0.91m/8ft×2.98ft work platform
Non-marking tire
Battery management system (ZA20JERT-Li Only)

ACCESS WITH ZOOMLION GREEN

Phone: 0086(731)-88353680 0086(731)-88250971
E-mail: awm@zoomlion.com

Add: ZOOMLION Wangcheng Industrial Park, Tengfei Road 997, Changsha, Hunan, China
Web: www.en.zoomlion.com

ROUGH TERRAIN ELECTRIC ARTICULATING BOOM LIFTS

NEW ROUGH TERRAIN

ZA20JERT/ZA20JERT-Li Comply with CE/ANSI/CSA Standard

Model	ZA20JERT		ZA20JERT-Li	
	Imperial	Metric	Imperial	Metric
Size				
Work Height	70ft 1in	21.38m	70ft 1in	21.38m
Platform Height	63ft 7in	19.38m	63ft 7in	19.38m
Horizontal Outreach	39ft 8in	12.1m	39ft 8in	12.1m
Up and Over Height	27ft 1in	8.25m	27ft 1in	8.25m
A - Stowed Length	28ft 10in	8.8m	28ft 10in	8.8m
B - Stowed Width	8ft 1in	2.46m	8ft 1in	2.46m
C - Stowed Height	8ft 3in	2.52m	8ft 3in	2.52m
D - Platform Length	Standard: 8ft Option: 6ft	Standard: 2.44m Option: 1.83m	Standard: 8ft Option: 6ft	Standard: 2.44m Option: 1.83m
E - Platform Width	Standard: 2ft 6in Option: 3ft	Standard: 0.76m Option: 0.91m	Standard: 2ft 6in Option: 3ft	Standard: 0.76m Option: 0.91m
F - Wheelbase	8ft 3in	2.52m	8ft 3in	2.52m
G - Ground Clearance	1ft 4in	0.4m	1ft 4in	0.4m
Performance				
Platform Capacity	550 lb/793 lb	250kg/360kg	550 lb/793 lb	250kg/360kg
Drive Speed	3.79 mph	6.1km/h	3.23 mph	5.2km/h
Gradeability	45%		45%	
Axles Oscillation	8in	0.20m	8in	0.20m
Turning Radius (Inside)	9ft 1in	2.78m	9ft 1in	2.78m
Turning Radius (Outside)	18ft	5.49m	18ft	5.49m
Turntable Swing	360° continuous		360° continuous	
Platform Rotation	±90°		±90°	
H-Tail Swing	2ft 1in	0.64m	2ft 1in	0.64m
Max. Working Slope	3°/5°		3°/5°	
Max. Wind Speed	28mph	12.5m/s	28mph	12.5m/s
Power				
Battery	24×2V/440Ah		48V/315Ah Li-ion battery	
Charger	48V/60A		48V/60A	
Drive Motor	AC 32V		AC 32V	
Lift Motor	AC 32V		AC 32V	
Auxiliary Power	12V DC Electrical pump		12V DC Electrical pump	
Hydraulic Tank Capacity	19.8 (us gal)	75L	19.8 (us gal)	75L
Tire				
Type	33×12 D610 Foam-filled tire		33×12 D610 Foam-filled tire	
Weight				
Gross	20392 lb	9250kg	20392 lb	9250kg

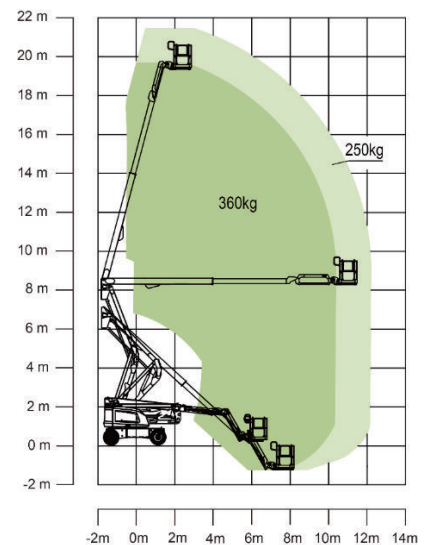
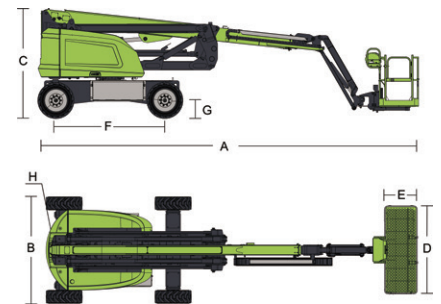

Range of Motion ZA20JERT/ZA20JERT-Li