

ZOOMLION ARTICULATING BOOM LIFTS

ZA10RJE

Comply with CE/ANSI/CSA Standard

HIGHLIGHTS



- ▶ Center layout, great structural rigidity, and small boom deflection
- ▶ Advanced dual control system (valve control + pump control) offers a energy-saving, smooth and efficient control
- ▶ Accurate and efficient permanent magnet synchronous motor provides strong power and stable control
- ▶ $\pm 90^\circ$ Jib rotation offers great up and over height
- ▶ Compact dimension of 1.2m stowed width, ideal for narrow working conditions
- ▶ Tubular batteries feature long working time and lifespan, and easy for maintenance

FEATURES

Standard Features

Proportional control	Load sensing system
All motion alarm	4.3' LED display
Flashing beacon	Horn
Self-closing entry gate	Timer
Emergency descent system	Jib rotation
Emergency stop button	Vertical lifting function
Auto-leveling system	Thumb joystick for steering
On-board diagnostic system	35A battery smart charger
Over tilt protection system	Electric quantity display
Solid seamless tire	Low electric quantity protection

Accessories & Options

- ▶ Platform light
- ▶ AC power to platform
- ▶ Air line to platform
- ▶ Electric auxiliary pump
- ▶ Platform console cover (Adjust rated capacity to 210kg)
- ▶ Secondary guarding system



ACCESS WITH ZOOMLION GREEN

Phone: 0086(731)-88353680 0086(731)-88250971
E-mail: awm@zoomlion.com

Add: ZOOMLION Wangcheng Industrial Park, Tengfei Road 997, Changsha, Hunan, China
Web: www.en.zoomlion.com

MAIN SPECS OF ARTICULATING BOOM LIFTS

ZA10RJE

Comply with CE/ANSI/CSA Standard

Model	ZA10RJE	
	Imperial	Metric
Dimension		
Work Height	37ft 11in	11.55m
Platform Height	31ft 4in	9.55m
Horizontal Outreach	20ft 6in	6.25m
Up and Over Height	15ft 1in	4.6m
A - Stowed Length	18ft 1in	5.5m
B - Stowed Width	3ft 11in	1.2m
C - Stowed Height	6ft 6in	1.98m
D - Platform Length	3ft 11in	1.19m
E - Platform Width	2ft 6in	0.76m
Jib length	4ft 1in	1.24m
F - Wheelbase	5ft 5in	1.65m
G - Ground Clearance	4in	0.1m
I - Transport Length (Jib tucked under)	13ft	3.95m
J - Transport Height (Jib tucked under)	8ft	2.45m
Performance		
Platform Capacity	507lb	230kg
Drive Speed	3.11mph	5km/h
Gradeability	35% (19°)	35% (19°)
Turning Radius (Inside)	5ft 7in	1.7m
Turning Radius (Outside)	10ft 8in	3.25m
Turntable Swing	355° non-continuous	
Jib Swing	±90°	
Platform Rotation	±90°	
H-Tail Swing	0m	
Max. Wind Speed	28mph	12.5m/s
Power		
Battery	24×2V/330Ah	
Charger	48V/35A	
Drive Motor	AC 48V/6hp	AC 48V/4.5kW
Lift Motor	DC 48V/6hp	DC 48V/4.5kW
Auxiliary Power	Standard: Manual pump Option: Electric pump	
Hydraulic Tank Capacity	3.96(us gal)	15L
Tire		
Type	22×7 seamless tire	
Weight		
Gross	14440lb	6550kg

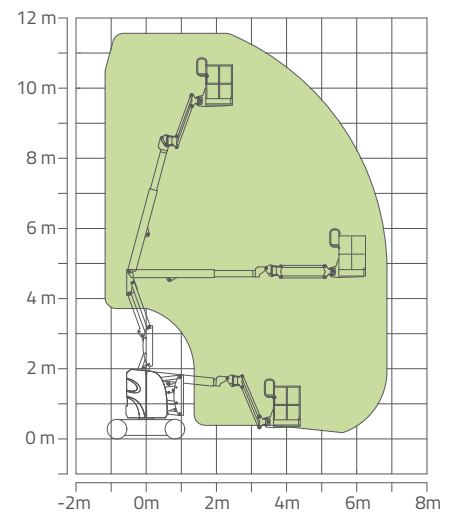
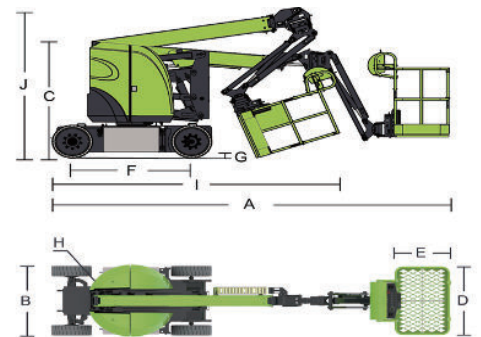

Range of Motion ZA10RJE

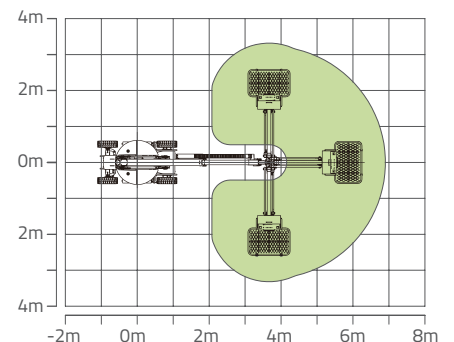

Range of Jib Swing Motion ZA10RJE