

# ZOOMLION TELESCOPIC BOOM LIFTS

## ZT26JE

Comply with CE/ANSI/CSA Standard

### HIGHLIGHTS

- ▶ Offer industry-leading dual capacity of 300kg/454kg.
- ▶ Customized lithium-ion battery features green, environmental protection, low noise and zero-emission, ideal for construction and plant maintenance.
- ▶ 606Ah lithium-ion batteries combined with excellent energy management system provide longer running time.
- ▶ Low-temperature regenerative current control and power self-adaptive control effectively improve the safety of Li-ion battery and greatly prolong the batteries service life of at least 10%.
- ▶ Provide a variety of standard charging plugs and 10A/16A/32A multi-power optional charging mode featuring strong charging adaptability.
- ▶ Brand-new appearance with lightweight GFRP composite material hood and integrally formed coating features anti-corrosion, heat preservation, aging resistance and easy cleaning.
- ▶ Assembled large-opening component box, open-close hood, and a variety of reserved inspection holes easy to service.
- ▶ Comply with GB and CE standards, up to 20 safety inspection functions, safer and more stable.
- ▶ Larger working envelope with 28.7m work height and 22.1m horizontal outreach.
- ▶ Accurate and efficient traveling AC drive system provides strong power and stable control. Gradeability reaches 45% and motor is maintenance-free for its lifetime.
- ▶ Meet the requirements of standard container transportation.

### FEATURES

#### Standard Features

Horn	Auto-leveling system
Proportional control	On-board diagnostic system
All motion alarm	Tilt protection system
Flashing beacon	Oscillating axle
Self-closing entry gate	Load sensing system
Emergency descent system	4.3' Led display
Emergency stop button	Swing-out engine tray

#### Accessories & Options

- ▶ Platform work light
- ▶ Secondary guarding system
- ▶ AC power to platform

## ACCESS WITH ZOOMLION GREEN

Phone: 0086(731)-88353680 0086(731)-88250971  
E-mail: awm@zoomlion.com

Add: ZOOMLION Wangcheng Industrial Park, Tengfei Road 997, Changsha, Hunan, China  
Web: www.en.zoomlion.com



# TELESCOPIC BOOM LIFTS

## ZT26JE

Comply with CE/ANSI/CSA Standard

Model	ZT26JE	
	Imperial	Metric
<b>Size</b>		
Work Height	94ft 2in	28.70m
Platform Height	87ft 7in	26.70m
Horizontal Outreach	82ft 6in	22.1m
A - Stowed Length	39ft 1in	11.91m
B - Stowed Width	8ft 2in	2.49m
C - Stowed Height	9ft 3in	2.82m
D - Platform Length	8ft	2.44m
E - Platform Width	3ft	0.91m
Jib length	6ft	1.83m
F - Wheelbase	9ft 2in	2.80m
Tread	6ft 11in	2.1m
G - Ground Clearance	1ft 4in	0.41m
<b>Performance</b>		
Platform Capacity (Unrestricted/Restricted)	660/1000lb	300/454kg
Drive Speed (Stowed)	3.42mph	5.5km/h
Gradeability	45%(24°)	
Turning Radius (Inside)	10ft 2in	3.11m
Turning Radius (Outside)	20ft 3in	6.16m
Turntable Swing	360° continuous	
Platform Rotation	±90°	
Tail Swing	5ft 3in	1.61m
Jib Rotation	130°(-55°~75°)	
Max. Wind Speed	28mph	12.5m/s
<b>Power</b>		
Battery	80V/606Ah	
Charger	6KW/80V	
Drive Motor	5.2KW	
Lifting Motor	30KW	
Auxiliary Power	12V DC	
Hydraulic Tank	32 US gal	120L
<b>Tire</b>		
Type	15-625 Foam-filled tire	
<b>Weight</b>		
Gross	39462lb	17900kg

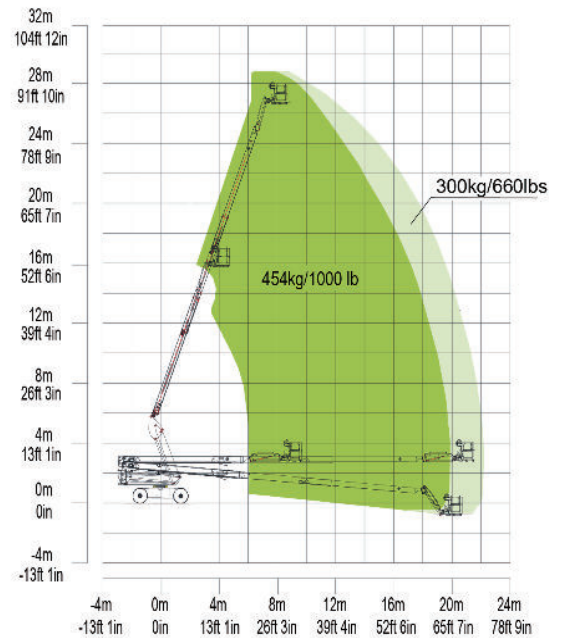
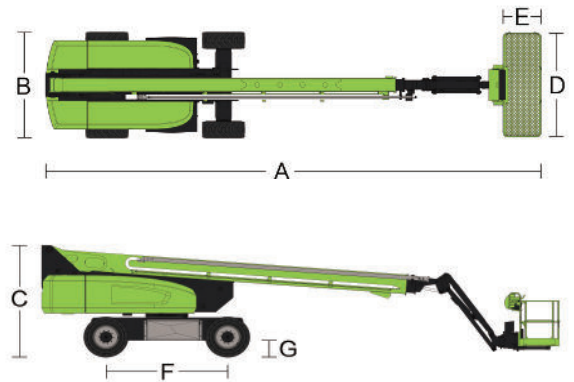

Range of Motion ZT26JE