

# ZOOMLION

## HYBRID ARTICULATING BOOM LIFTS

### ZA24JH

Comply with CE Standard

#### HIGHLIGHTS

- ▶ Plug-in hybrid articulating boom lift features long running time and low emission
- ▶ Electric mode almost suitable for every sector, hybrid mode provides stronger off-road capability
- ▶ AGM batteries offer large capacity with long working time and maintenance-free feature
- ▶ Offer industry-leading work height of 26.5m, a horizontal outreach of 18.9m, and a up and over height of 9.42m
- ▶ Platform fast lifting function provides extreme maneuverability
- ▶ Outstanding below ground reach of 5.1m
- ▶ Provide a hydraulic system with multi-way valve for accurate control



#### FEATURES

##### Standard Features

Proportional control	Auto-leveling system
All motion alarm	On-board diagnostic system
Flashing beacon	Over tilt protection system
Self-closing entry gate	Load sensing system
Emergency descent system	4.3' LED display
Emergency stop button	Horn

##### Accessories & Options

- ▶ Work light
- ▶ AC power to platform
- ▶ Air line to platform

## ACCESS WITH ZOOMLION GREEN

Phone: 0086(731)-88353680 0086(731)-88250971  
E-mail: awm@zoomlion.com

Add: ZOOMLION Wangcheng Industrial Park, Tengfei Road 997, Changsha, Hunan, China  
Web: www.en.zoomlion.com

# HYBRID ARTICULATING BOOM LIFTS

## ZA24JH

Comply with CE Standard

Model	ZA24JH	
	Imperial	Metric
<b>Size</b>		
Work Height	86ft 11in	26.5m
Platform Height	80ft 5in	24.5m
Horizontal Outreach	62ft	18.9m
Up and Over Height	30ft 11in	9.42m
A - Stowed Length	36ft 9in	11.2m
B - Stowed Width	8ft 2in	2.49m
C - Stowed Height	9ft 10in	3m
D - Platform Length	8ft	2.44m
E - Platform Width	2ft 12in	0.91m
F - Wheelbase	10ft	3.05m
G - Ground Clearance	1ft 5in	0.42m
<b>Performance</b>		
Platform Capacity	510lb	230kg
Drive Speed	3.11 mph	5km/h
Gradeability	45%	
Axles Oscillation	8in	0.20m
Turning Radius (Inside)	11ft	3.35m
Turning Radius (Outside)	21ft 3in	6.48m
Turntable Swing	360° continuous	
Platform Rotation	±90°	
H-Tail Swing	3ft 9in	1.15m
Max. Working Slope	4°	
Max. Wind Speed	27.96mph	12.5m/s
<b>Power</b>		
Engine	Kubota	
Battery	AGM Maintenance-free	
Control Voltage	12V	
Fuel Tank Capacity	39.6 (us gal)	150L
Hydraulic Tank Capacity	47.6 (us gal)	180L
<b>Tire</b>		
Type	15-625 Foam-filled Tires	
<b>Weight</b>		
Gross	39242 lb	17800kg

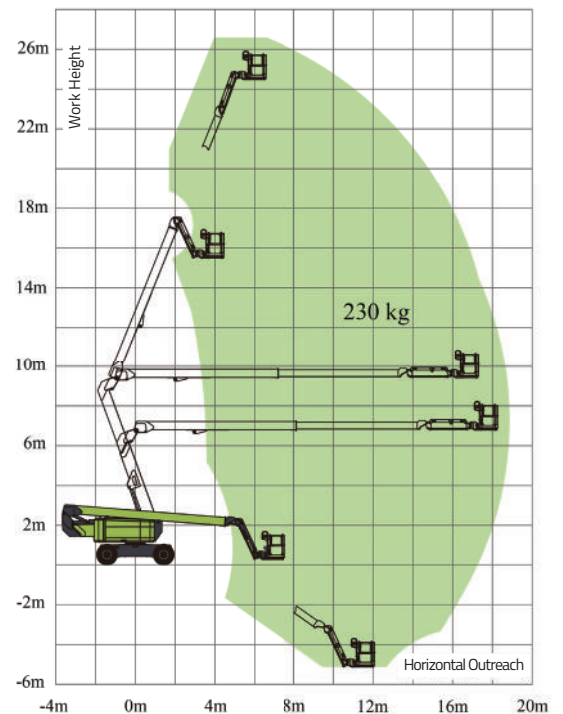
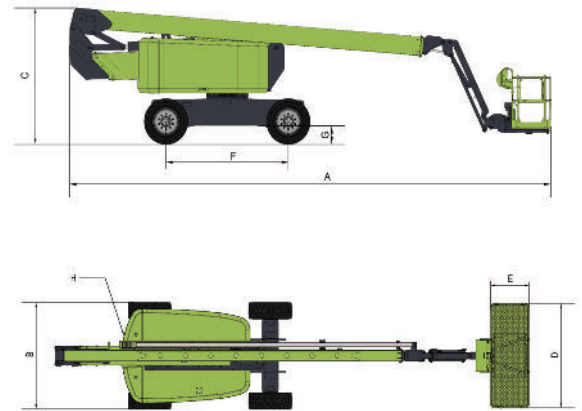

Range of Motion ZA24JH